

## Underground Mains and Detectable Marking Tape increases safety by indicating the contents of pipes.

Constructed from polyethylene, the tape is rot and fade resistant and is available in any width and length.

Color coded tapes conform to Australian Standards and stretches rather than tearing when hooked by a shovel or backhoe.

Detectable marking tape is available, containing an electronically continuous 0.7mm stainless steel wire trace which has 50% exposure to soil for easy detection.

Standard widths include 100 & 150mm, with standard lengths varying from 50, 100, 250 and 500 meters for non-detectable tape and 100, 250 and 300 meters for detectable marking tape.

Non-Standard lengths may require a longer lead time to allow for manufacture.



### UNDERGROUND WARNING TAPE - X 150MM

PART NO.	Description
WMI-100UWT-ORANGE	Underground Warning Tape 100m roll
WMI-100UWT-WHITE	Underground Warning Tape 100m roll
WMI-500UWT-ORANGE	Underground Warning Tape 500m roll
WMI-500UWT-WHITE	Underground Warning Tape 500m roll



### DETECTABLE WARNING TAPE - WITH TRACER WIRE X 150MM

PART NO.	Description
WMI-250DWT-ORANGE	Detectable Warning Tape 250m roll
WMI-250DWT-WHITE	Detectable Warning Tape 250m roll
WMI-500DWT-ORANGE	Detectable Warning Tape 500m roll
WMI-500DWT-WHITE	Detectable Warning Tape 500m roll

## WMIS is Australia and New Zealand's largest supplier of underground cable cover.

WMIS cable cover is manufactured to AS / NZ 4702-2000. Our metal detectable cable cover is manufactured to the Australian standard with the inclusion of our Detectable marking tape. Using a 0.7mm AS 316 grade stainless steel tracer wire, this electronically continuous wire has 50% exposure to the soil allowing easy detection.

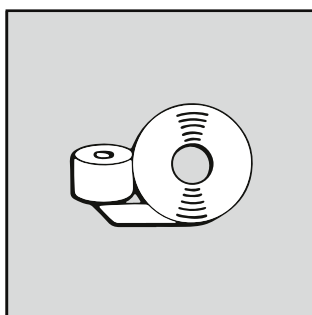

### CABLE COVER

PART NO.	Description
WMI-150CC5	150mm x 5mm x 25mtr Roll
WMI-200CC5	200mm x 5mm x 25mtr Roll
WMI-300CC5	300mm x 5mm x 20mtr Roll

# UNDERGROUND MAINS MARKING TAPE

Underground Mains Marking Tape / Detectable Underground Mains Marking Tape / Printed Barrier Tape / Adhesive Floor Marking Tape

## Pipeline identification assists contractors & the general public know the contents of pipes that they may encounter.

100% Australian owned & made to Australian Standards.

Polyethylene tape is rot & fade resistant

Standard widths are 100mm & 150mm with any length possible

Customised widths & messages are also available

**DANGER**  
**ELECTRICAL CABLE BELOW**

← UNDERGROUND WARNING TAPE  
WMI-100UWT / WMI-500UWT

**CAUTION - CAUTION**  
RECYCLED - RECLAIMED WATER DO NOT DRINK

**CAUTION - CAUTION**  
FIRE FIGHTING MAIN BELOW

**DANGER - SEWER MAIN BELOW**

**DANGER**  
HIGH PRESSURE OIL PIPELINE

**DANGER - IRRIGATION MAIN BELOW**

**CAUTION - WATER MAIN BELOW**

**DANGER - STORMWATER MAIN BELOW**

**DANGER - GAS MAIN BELOW**

3 way tape, 200mm wide

**WARNING**  
TELECOMMUNICATIONS  
NATURAL GAS MAINS  
ELECTRICITY CABLES

**DANGER - FIBRE OPTIC COMMUNICATION CABLE BELOW**

← DETECTABLE WARNING TAPE  
WMI-250DWT / WMI-500DWT - TRACER WIRE

**WARNING WARNING**  
COMMUNICATION CABLE BELOW

**- CAUTION - WATER MAIN BELOW**

It is recommended to place this product directly above pipes & cables being installed, allowing for easy detection by future users.

- 100% Australian owned & made to Australian Standards
- Polyethylene tape is rot & fade resistant
- Stainless Steel tracer wire
- Standard sizes are 100mm wide, in lengths of 100, 250 or 300 metres
- Available in all messages as shown above
- Customised messages & messages available on request
- Dispensable box allows for easy use & storage